

Light Detector using Transistor

Introduction :

A Light Detector or a Light Sensor is a device or circuit that detects the intensity of the light incident on it. Different types of light detectors are LDRs (or Light Dependent Resistors), Photo Diodes, Photo Transistors, etc. All these devices are called as Photoelectric Devices as they convert light energy to electric energy. These Light Detectors or Sensors can detect different types of light like visible light, ultraviolet light, infrared light etc. In this project, we have designed a simple Light Detector using LDR. When the light falls on the LDR, the light stays off and when the light stops falling on LDR, the LED glows.

Circuit Diagram :

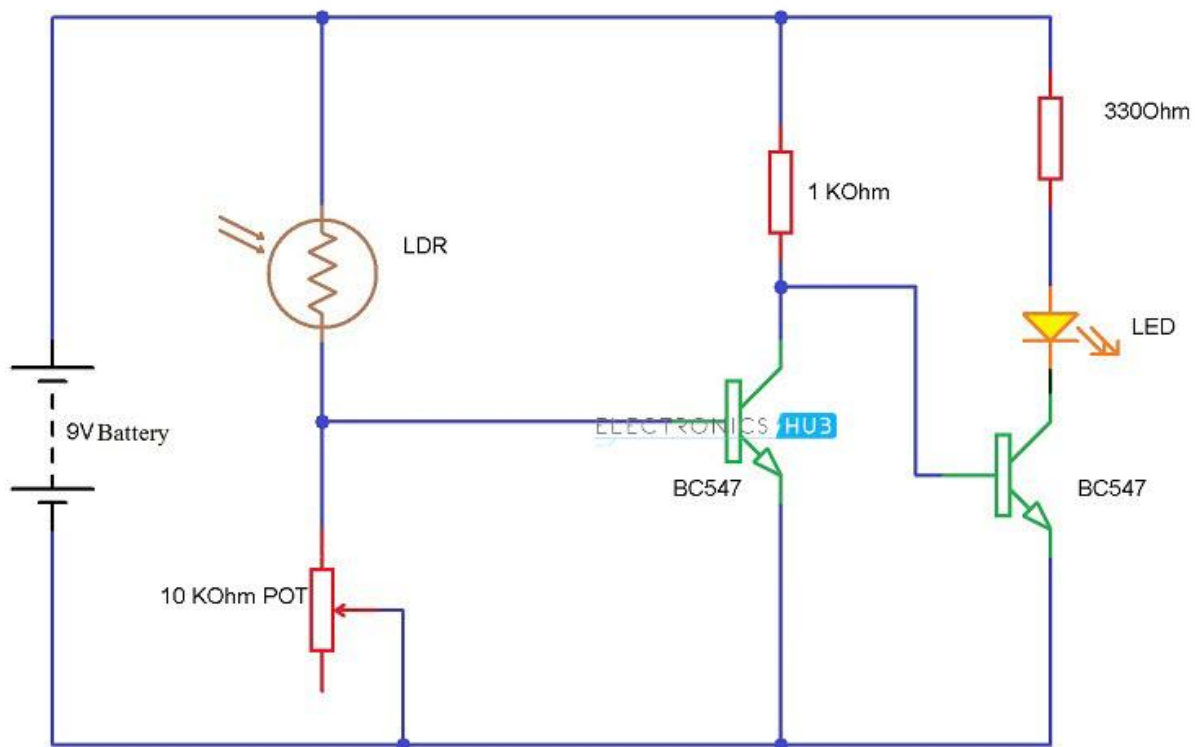

Components Required :

- 2 x BC547 NPN Transistors
- Small LDR
- 1 K Ω Resistor
- 10 K Ω Potentiometer
- White LED
- 330 Ω Resistor
- Connecting wires
- Power supply (9V Battery)

Applications :

- Simple Light Detector Circuit can be used in many applications like automatic switching of appliances up on detecting light, security systems, etc.
- This circuit can be used in alarm system, where increasing intensity of light will trigger the alarm.
- It can also be used in cupboards or wardrobes. When the door is opened, the light will automatically turned on.